

2014



ULTIMATE WIDESCREEN BARTOP

ASSEMBLY INSTRUCTIONS

VERSION 1.0

HARUMANCUSTOMS.COM

Ultimate Widescreen Assembly Instructions



Tools & Materials Needed:

- Rubber Mallet
- Screwdriver
- Wood Glue
- Drill & Assorted Drill bits
- Rags

Main Cabinet Assembly:

Unpack the box and locate the following parts and lay them out on a clean hard surface:

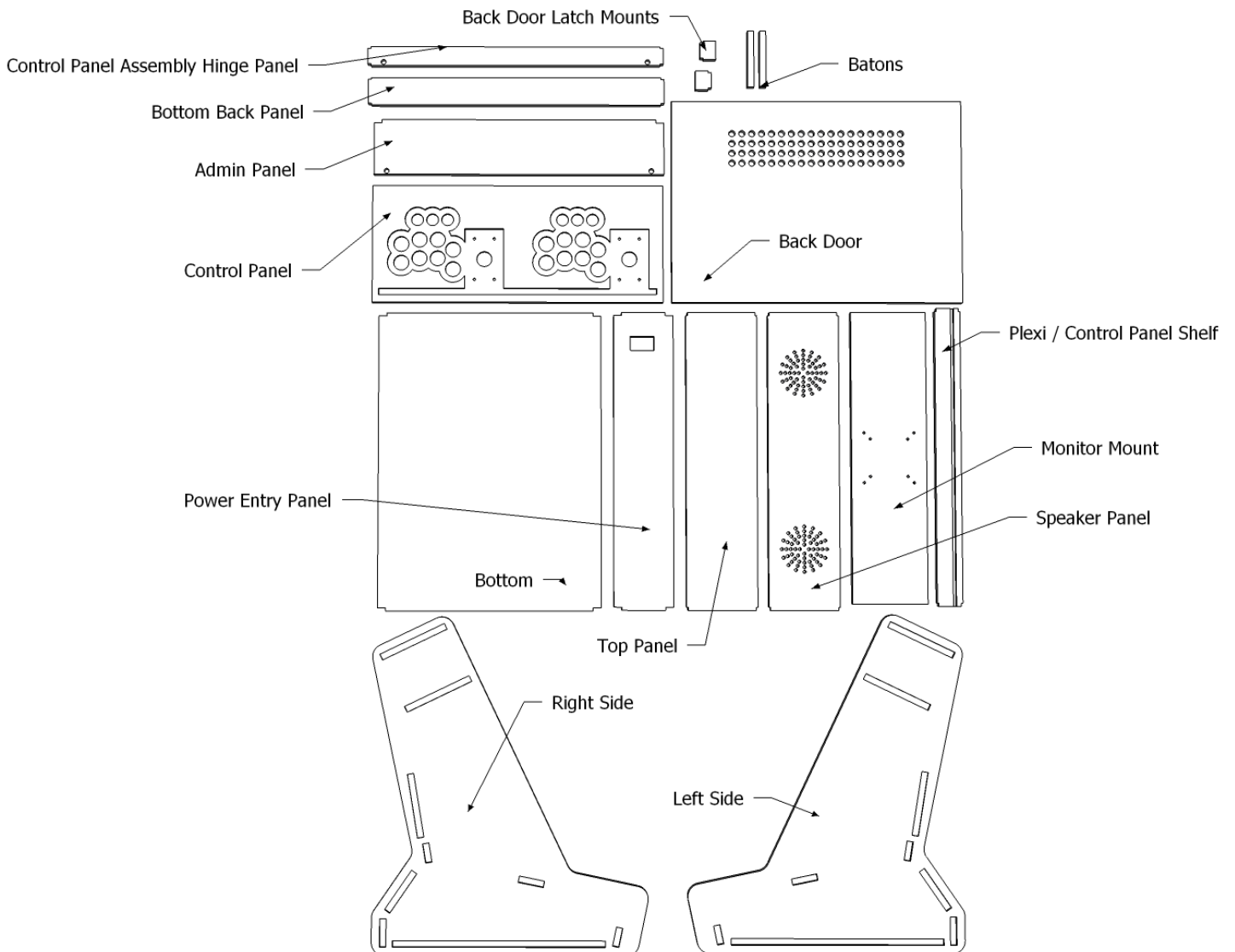

Take the wood glue and insert into the areas marked red on the right side:

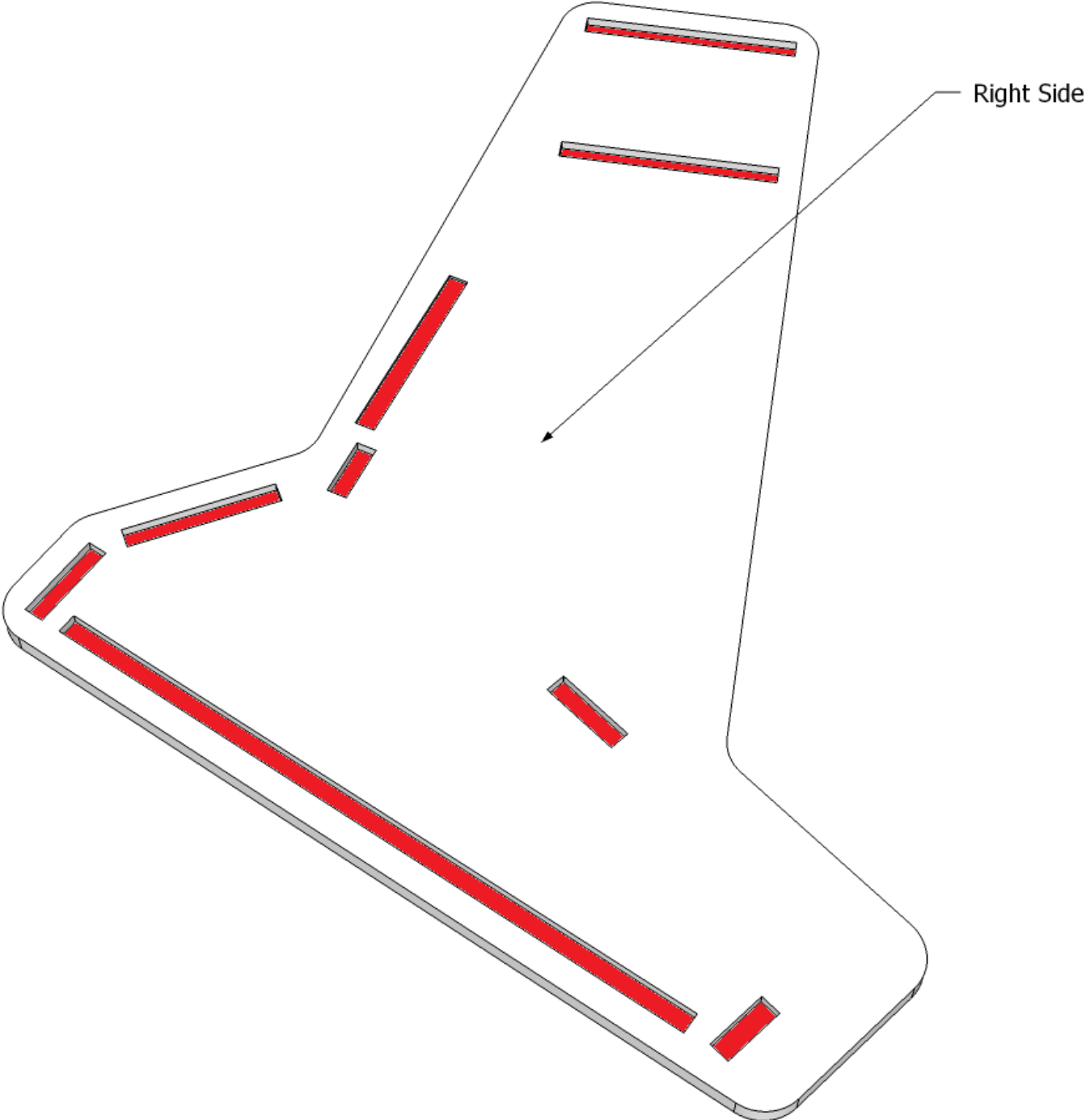

Insert the Control Panel Assembly Hinge Panel into the Right Side as shown. Make sure that two small holes are near the bottom and facing out:

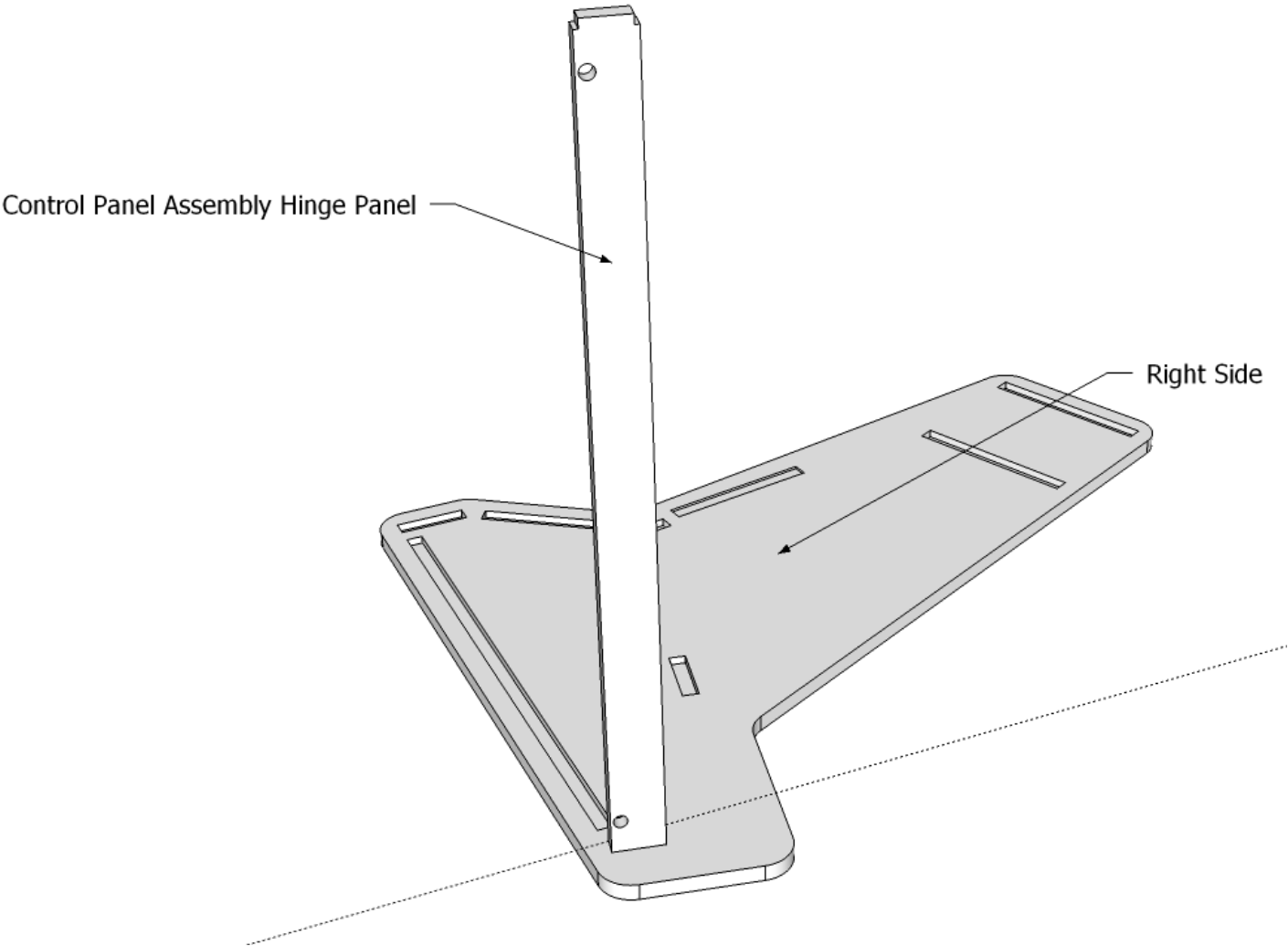

Next, insert the Plexi / Control Panel Shelf as shown, with the plexi slot facing UP and closest to the rear of the cabinet:

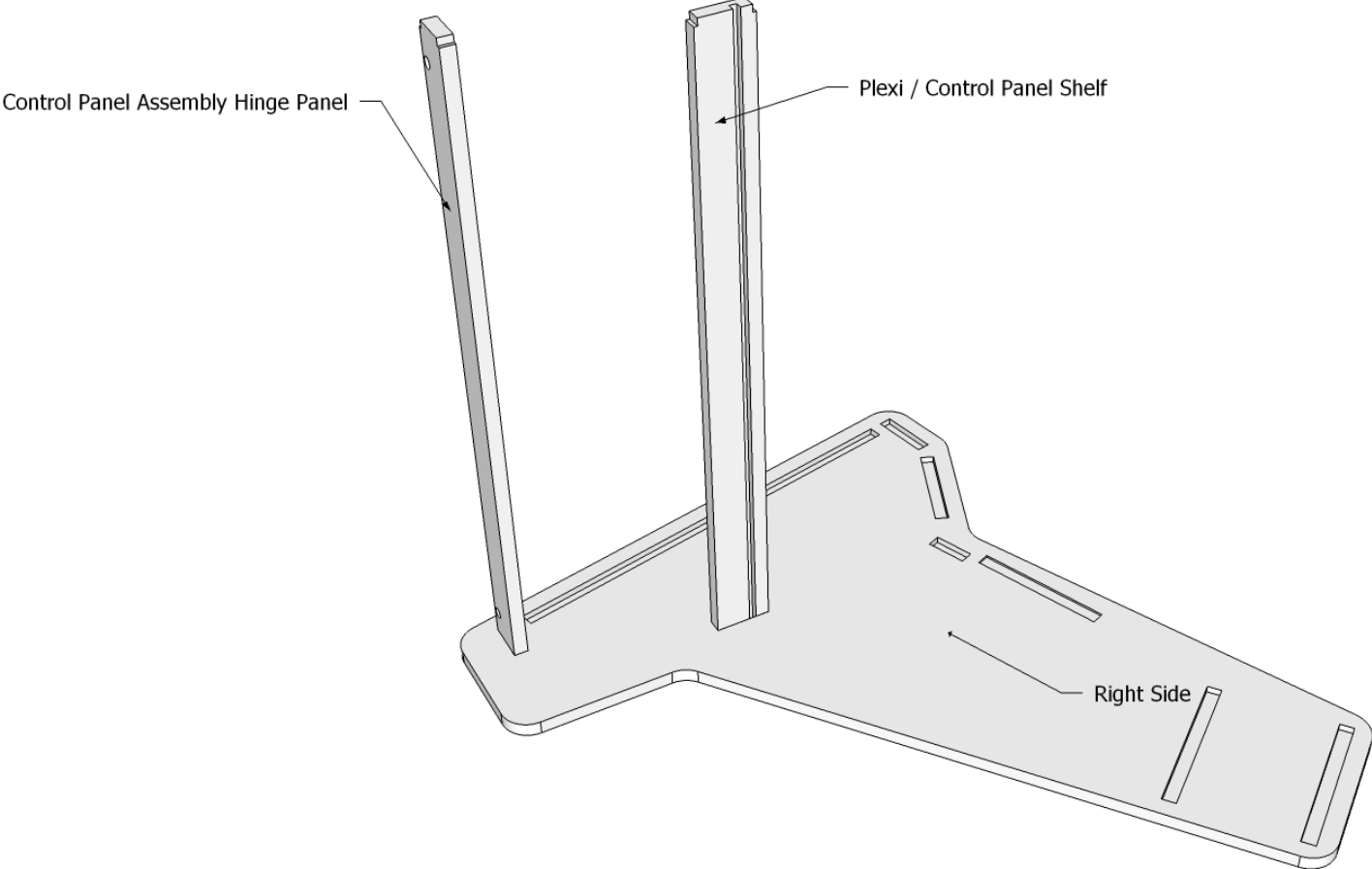

Insert the Bottom Panel, Bottom Back Panel, and the Power Entry Panel as shown:

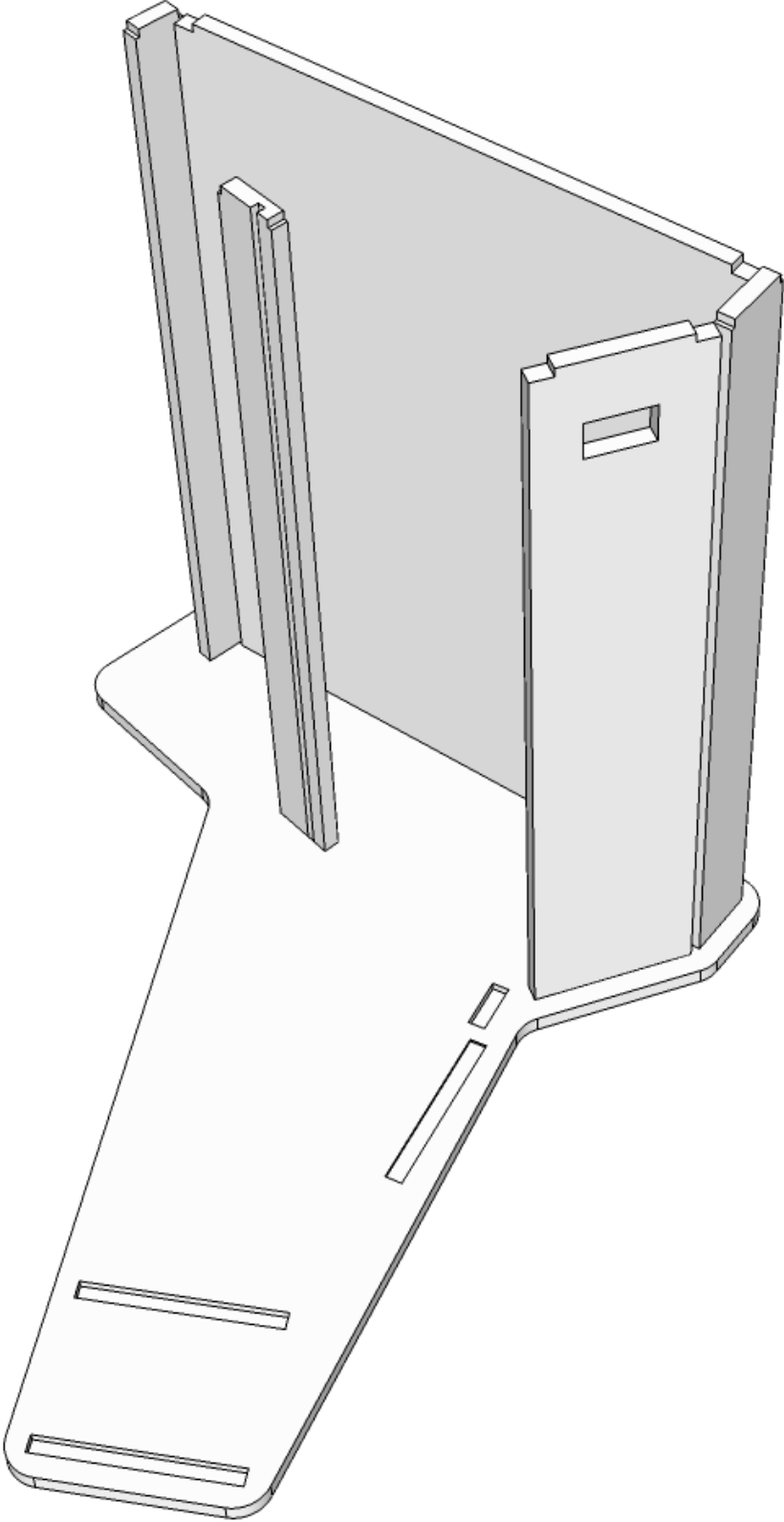

Insert Baton and Back Door Latch Mount into the side as shown.

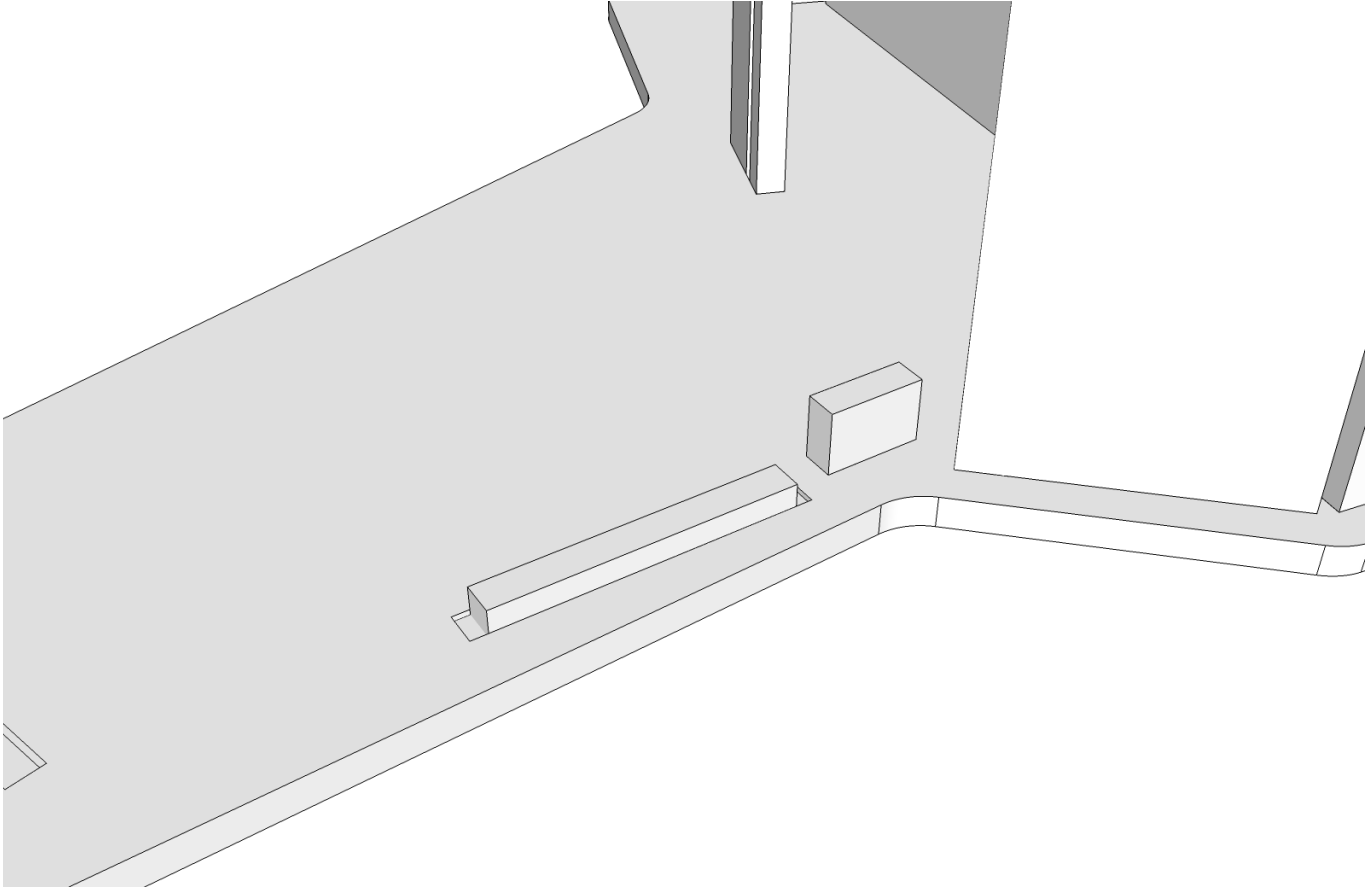

Insert Top and Speaker Panels as shown:

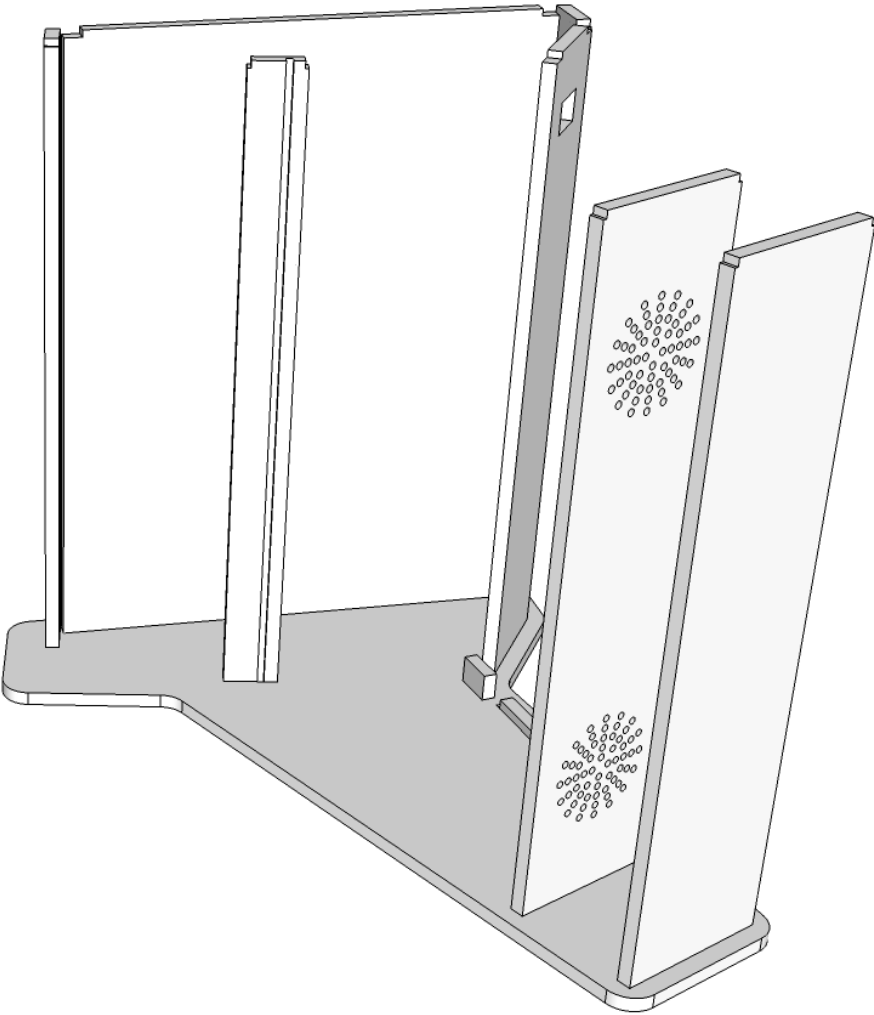

Carefully place the remaining side on top (no glue at this time) and line up all the tabs into the slots. When the tabs and slots are aligned, press down. Place a weight on top of the side to apply pressure. Take this time to wipe up any excess glue that may seep from the slots. Let dry overnight.

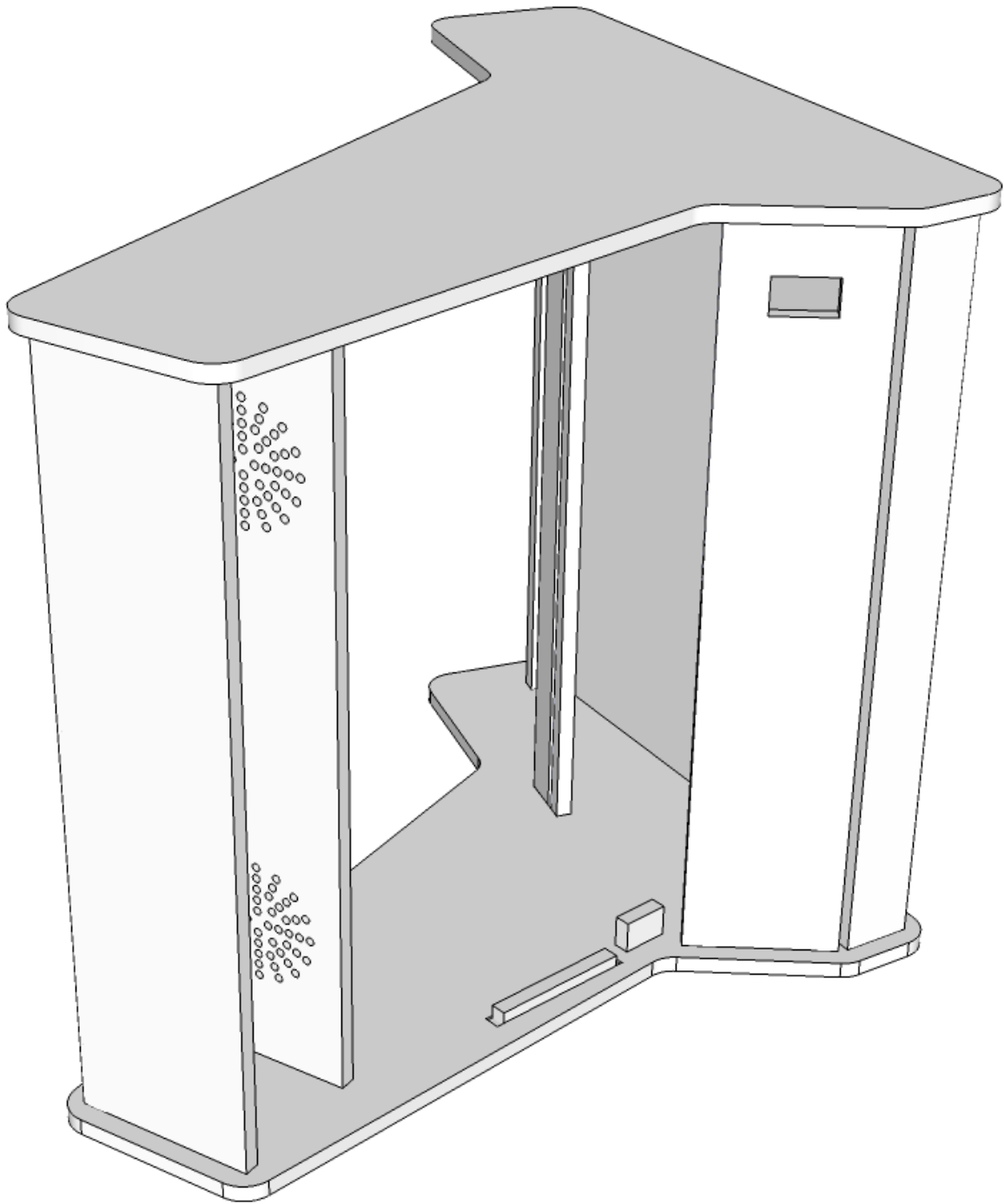

Once the glue has dried overnight, remove the weight and remove the side that wasn't glued. Place that side down on a flat surface, slots facing up, and add glue into the slots. Carefully turn over the glued side / panels assembly and insert the tabs into the correct slots, press down, add a weight, and wipe up any excess glue. Also insert the remaining Baton and Back Door Latch Mount. Let dry overnight.

Control / Admin Panel Assembly:

Take the wood glue and insert into the areas marked red:

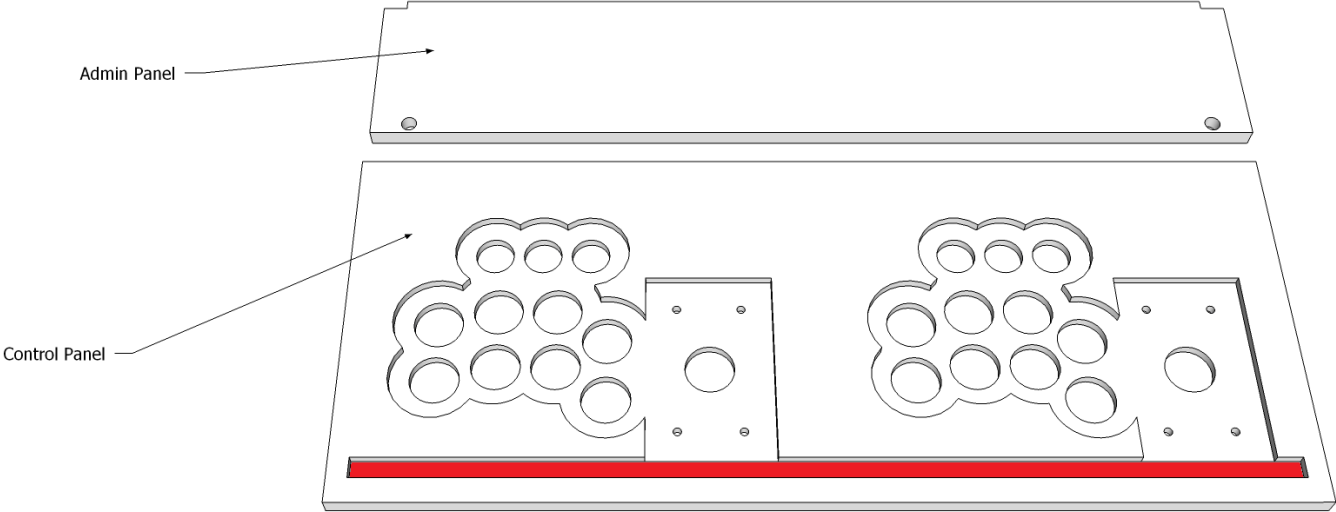

Insert tab of the Admin Panel in to the slot on the Control Panel as shown. Make sure the small holes at the bottom of the Admin Panel are facing the back of the Control Panel! Press down to ensure correct fit. Wipe up and excess glue and let dry overnight.

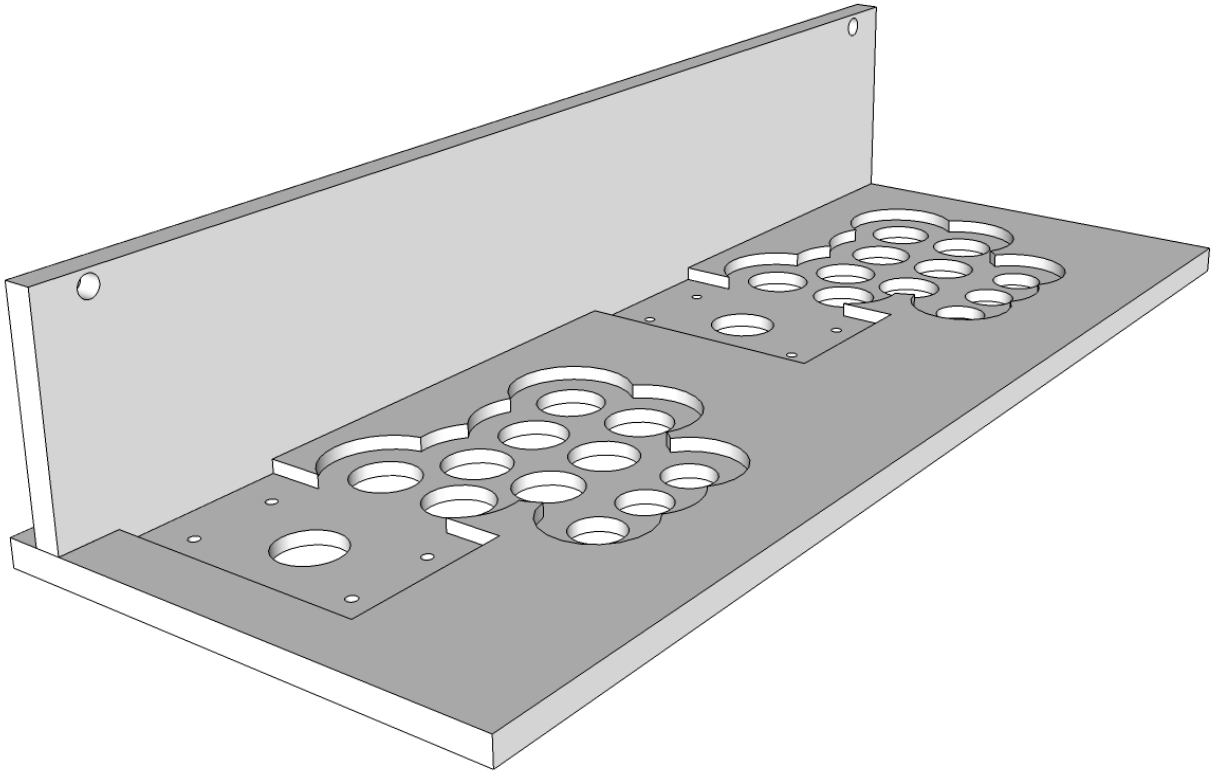

Once cabinet and control panel has dried, take a barrel hinge and open it up so that one end points down, like so:

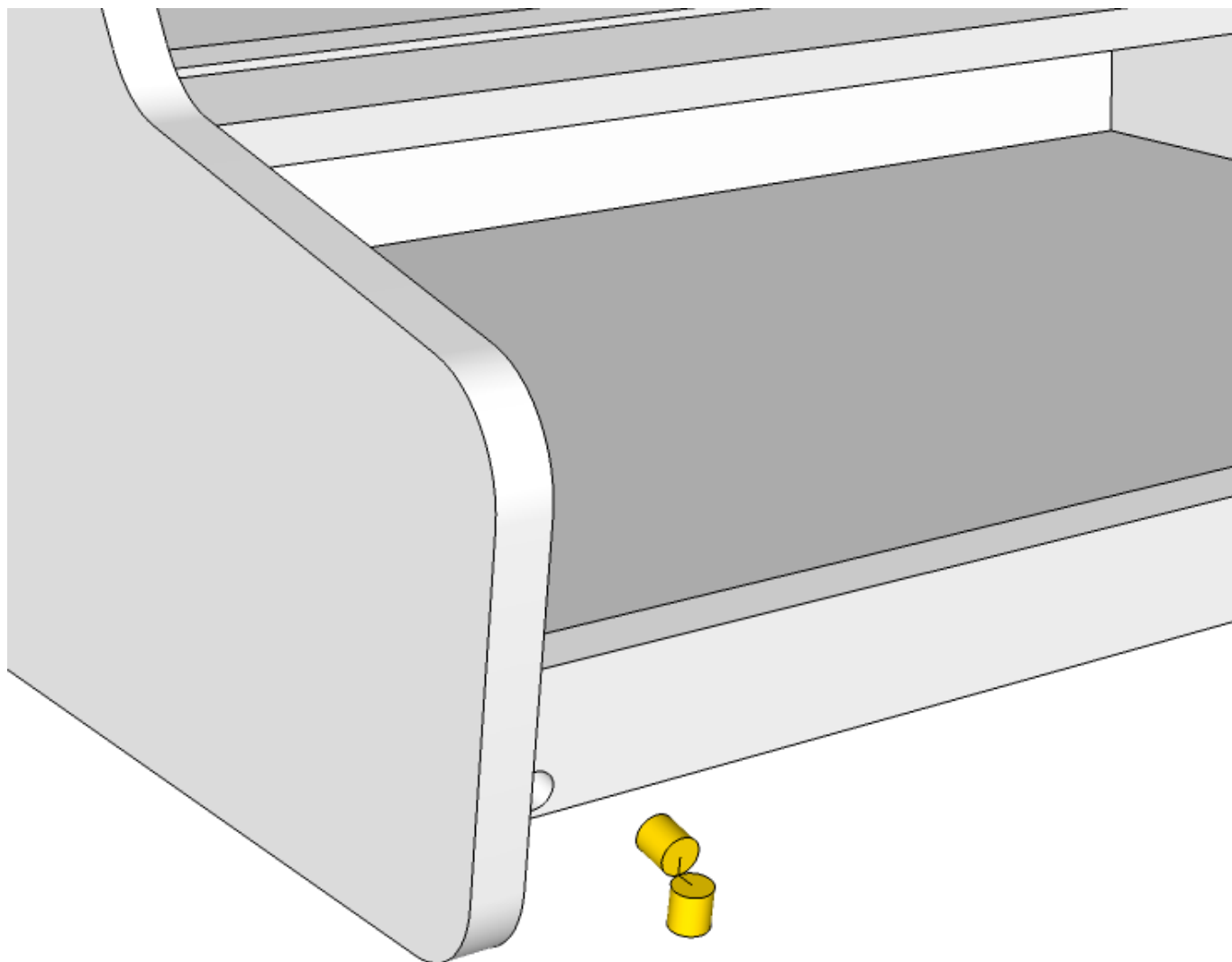

Insert the barrel hinge into the hole on the cabinet. Ensure that the open part of the hinge still faces down. Repeat for both sides of the cabinet.

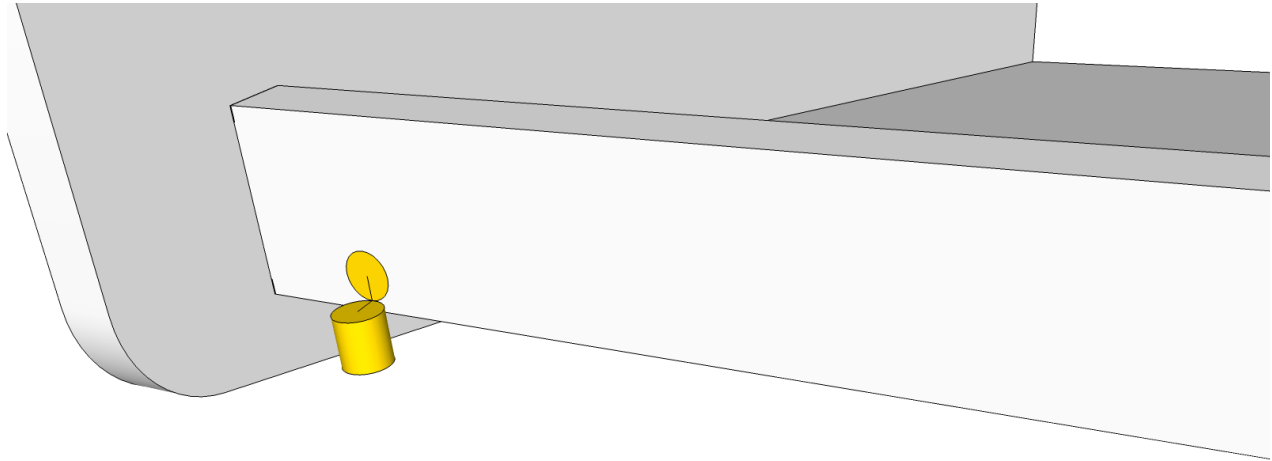

Close both hinges so they stick straight out from the panel. At this time, take the control panel assembly, line up the holes on the admin panel with the barrel hinges, and press the control panel onto the hinges.

Next, install the magnet latches close to the sides of the cabinet by drilling a small pilot hole into the control panel shelf and attach the steel magnet cup using the screw provided. Once installed, place the magnet in the cup. Install the steel washer to the bottom of the control panel so that it will sit on top of the magnet when the control panel is closed.

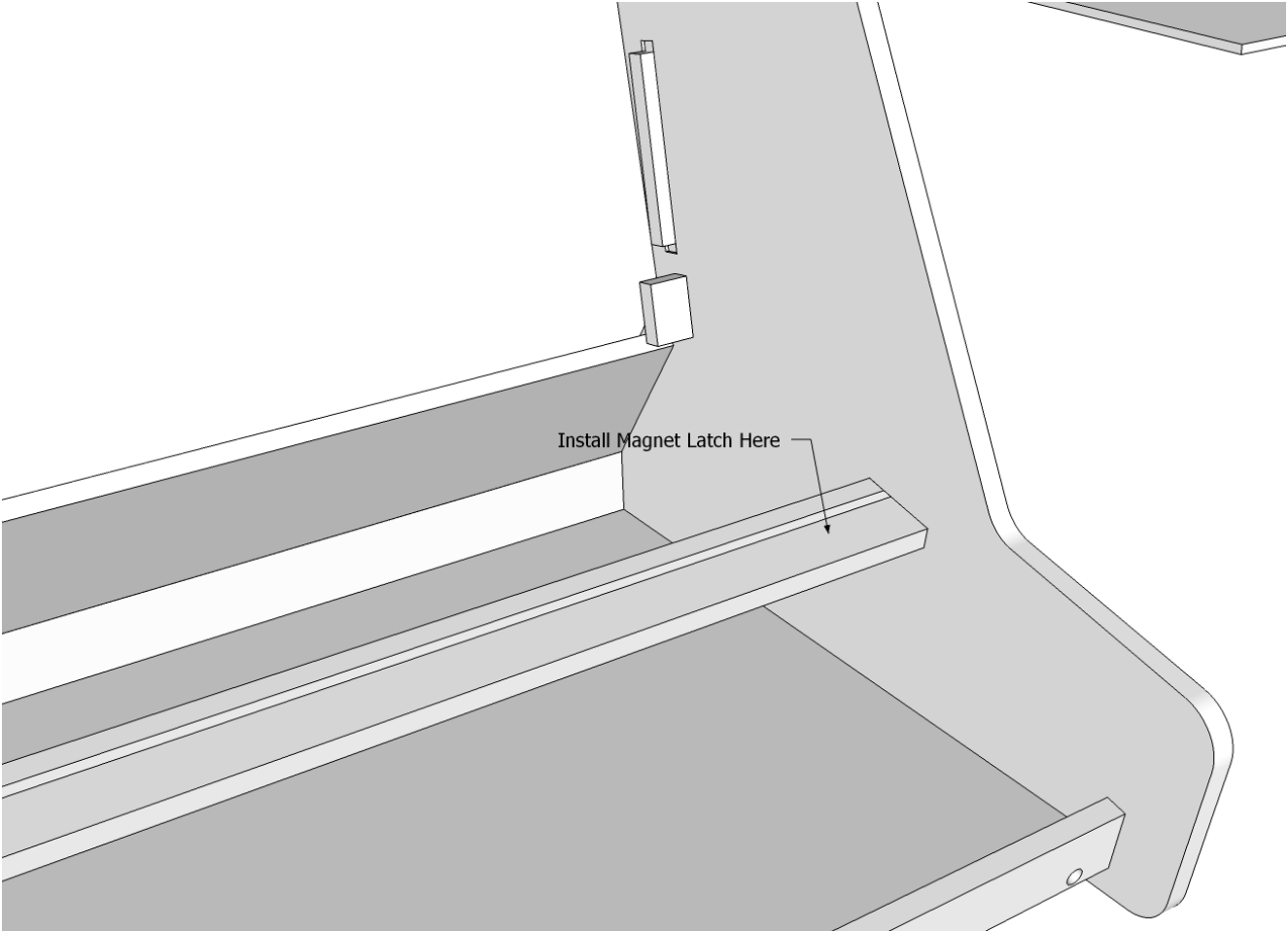

Monitor mounting:

Once completed and dry, lay the bartop face down (marquee & control panel area closest to the ground).

Once down, place the plexiglass inside, one side will rest in the slot on the plexi shelf, the other side will need to be propped up with books to the angle desired for monitor mounting.

Attach the monitor to the VESA mount panel using M4-.07 machine screws (25mm length). Place the monitor & panel inside the bartop resting on the plexiglass. Adjust the placement so the monitor is visible. Use the included angle brackets to attach the panel to the inside of the cabinet.

*** NOTE :** The included screws with the brackets are a little too long and will poke out of the cabinet if you use them as is. You either need shorter screws or use some spacers (like washers).

