

2014



NINTENDO BARTOP

ASSEMBLY INSTRUCTIONS

VERSION 1.0

HARUMANCUSTOMS.COM

Nintendo Assembly Instructions



Tools & Materials Needed:

- Rubber Mallet
- Screwdriver
- Wood Glue
- Drill & Assorted Drill bits
- Rags

Main Cabinet Assembly:

Unpack the box and locate the following parts and lay them out on a clean hard surface:

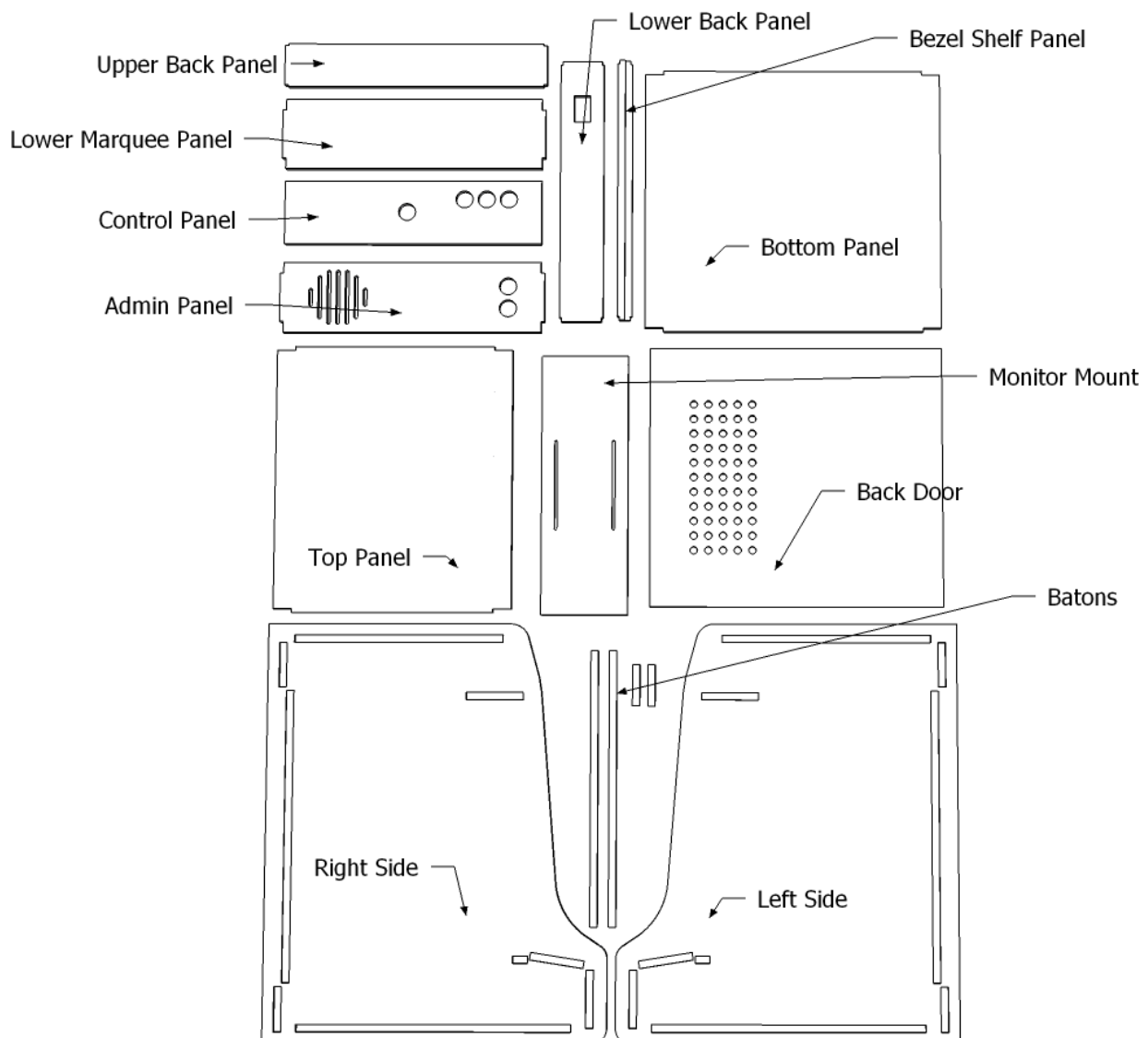

Take the wood glue and insert into the areas marked red on the right side:

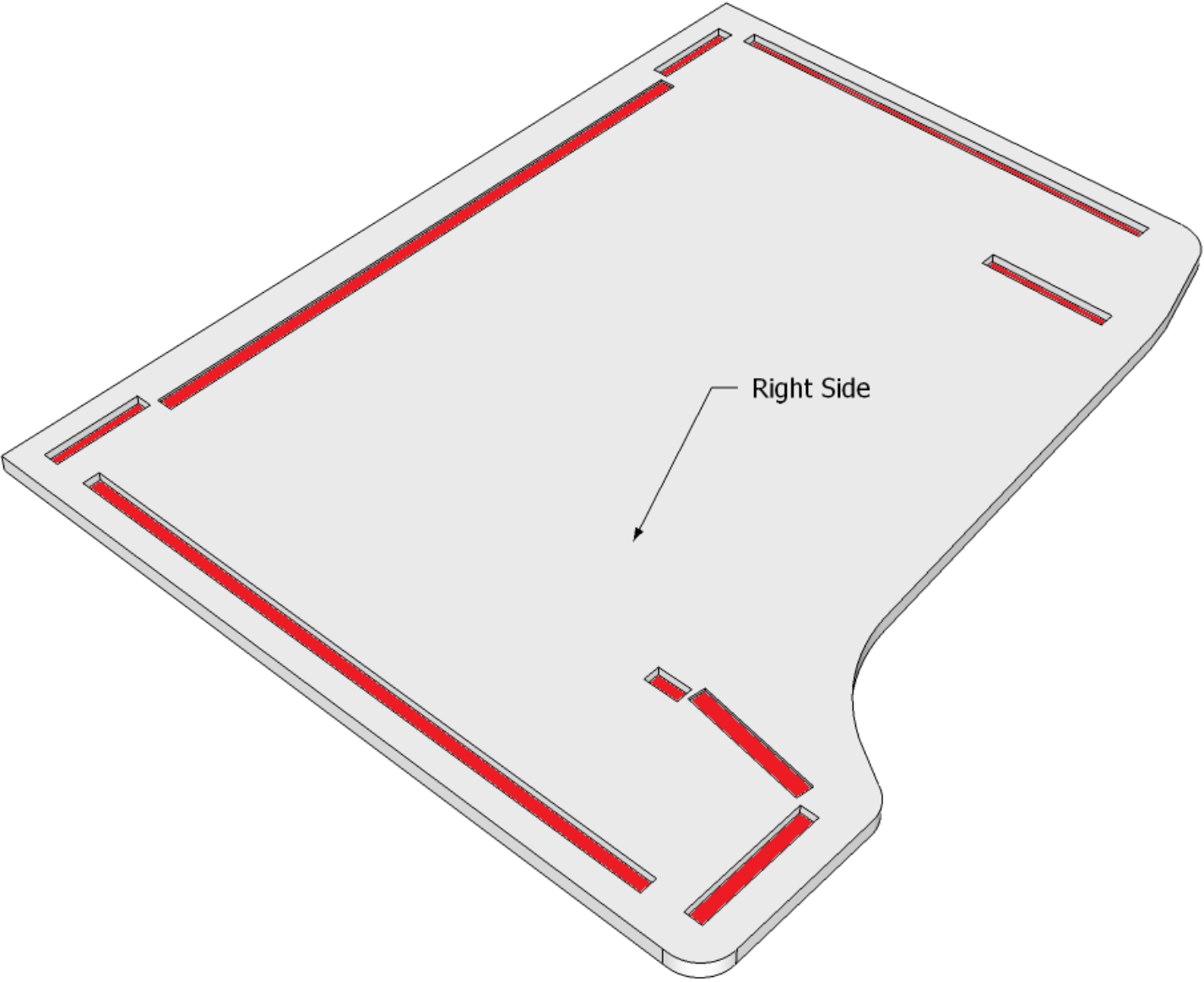

Insert the Admin Panel and Bottom Panel into the Right Side. Make sure that speaker cutout is near the top:

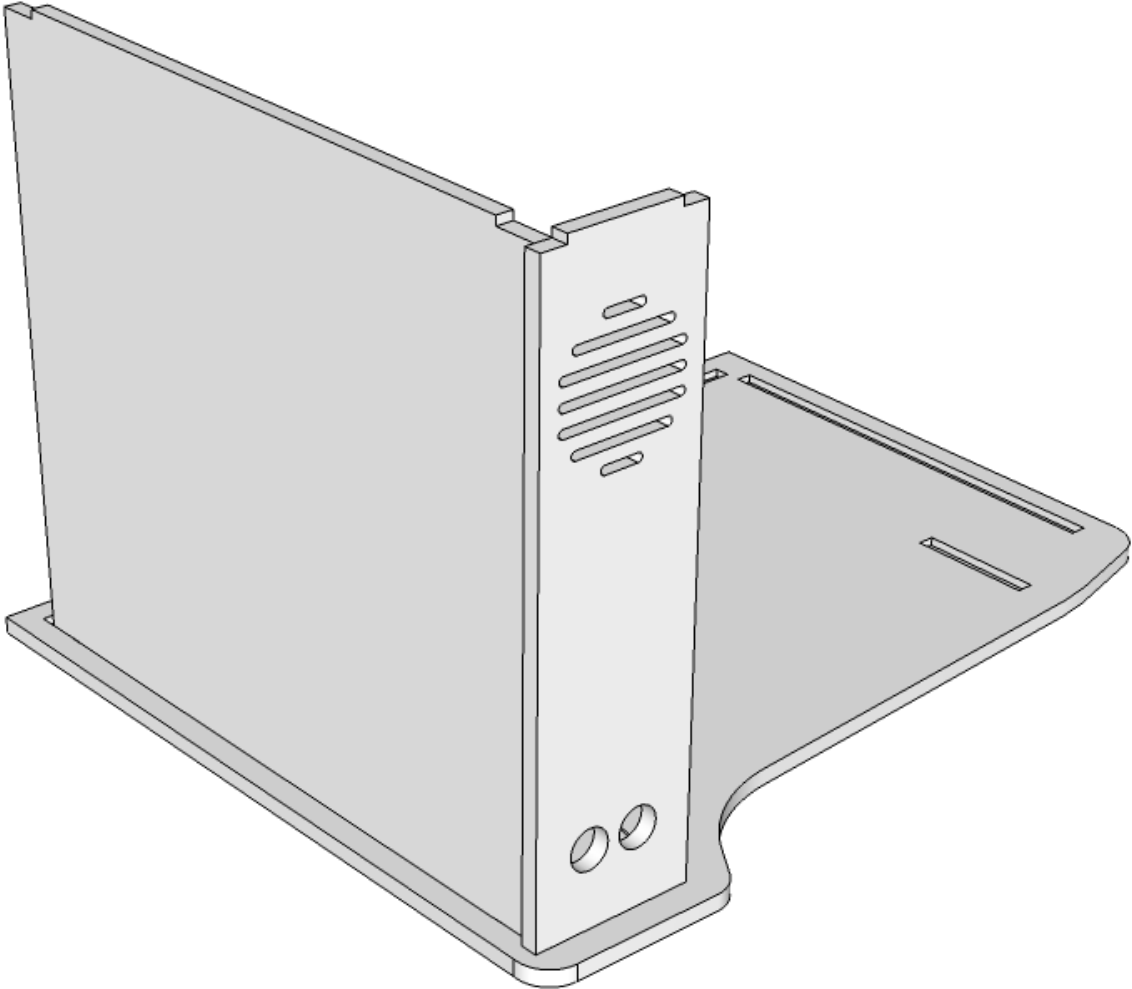

Next, insert the Bezel Shelf Panel as shown, with the plexi slot facing UP and closest to the rear of the cabinet (note the part has been colored to help with visualization):

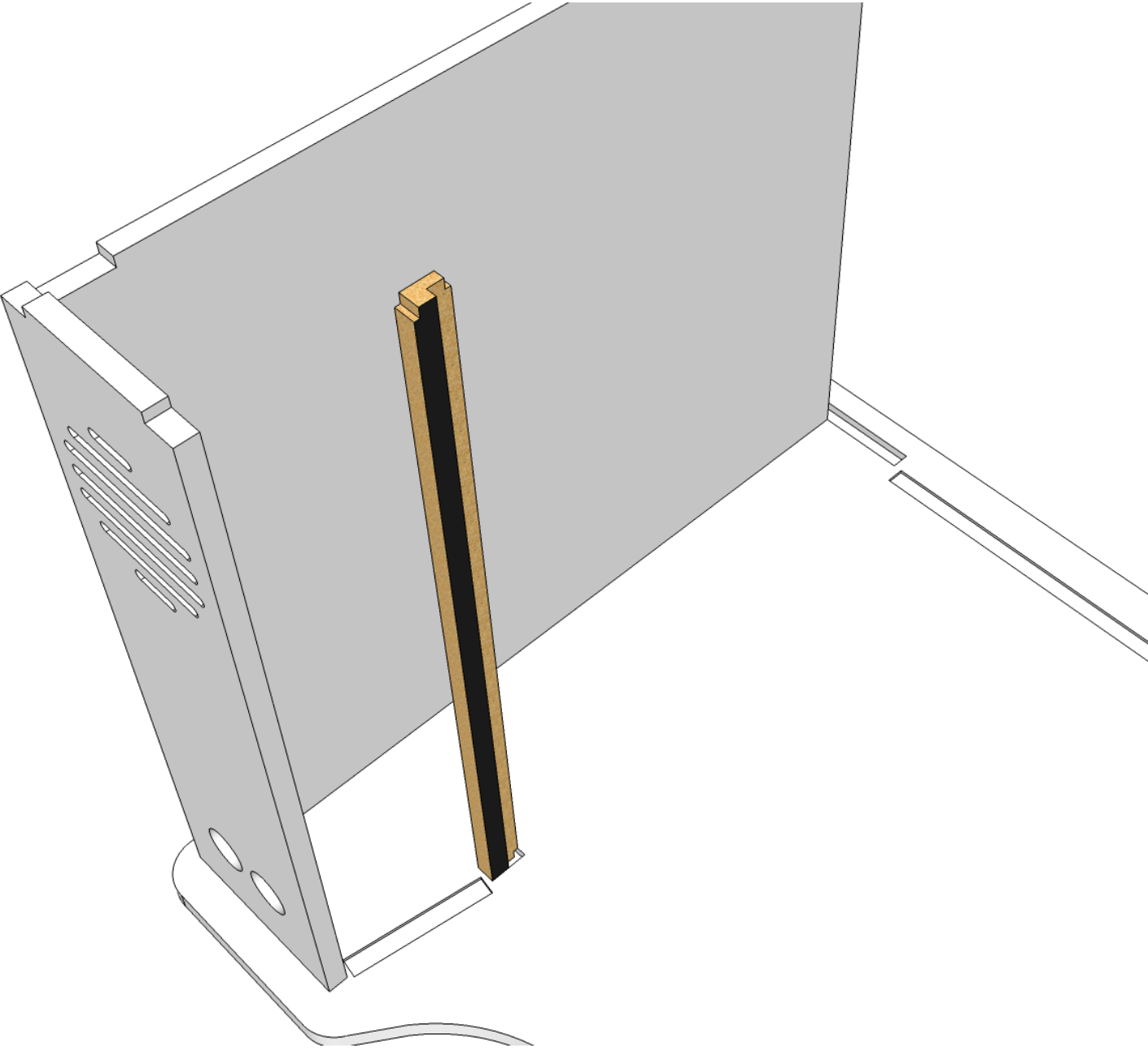

Insert the Upper Back and Lower Back Panel as shown:

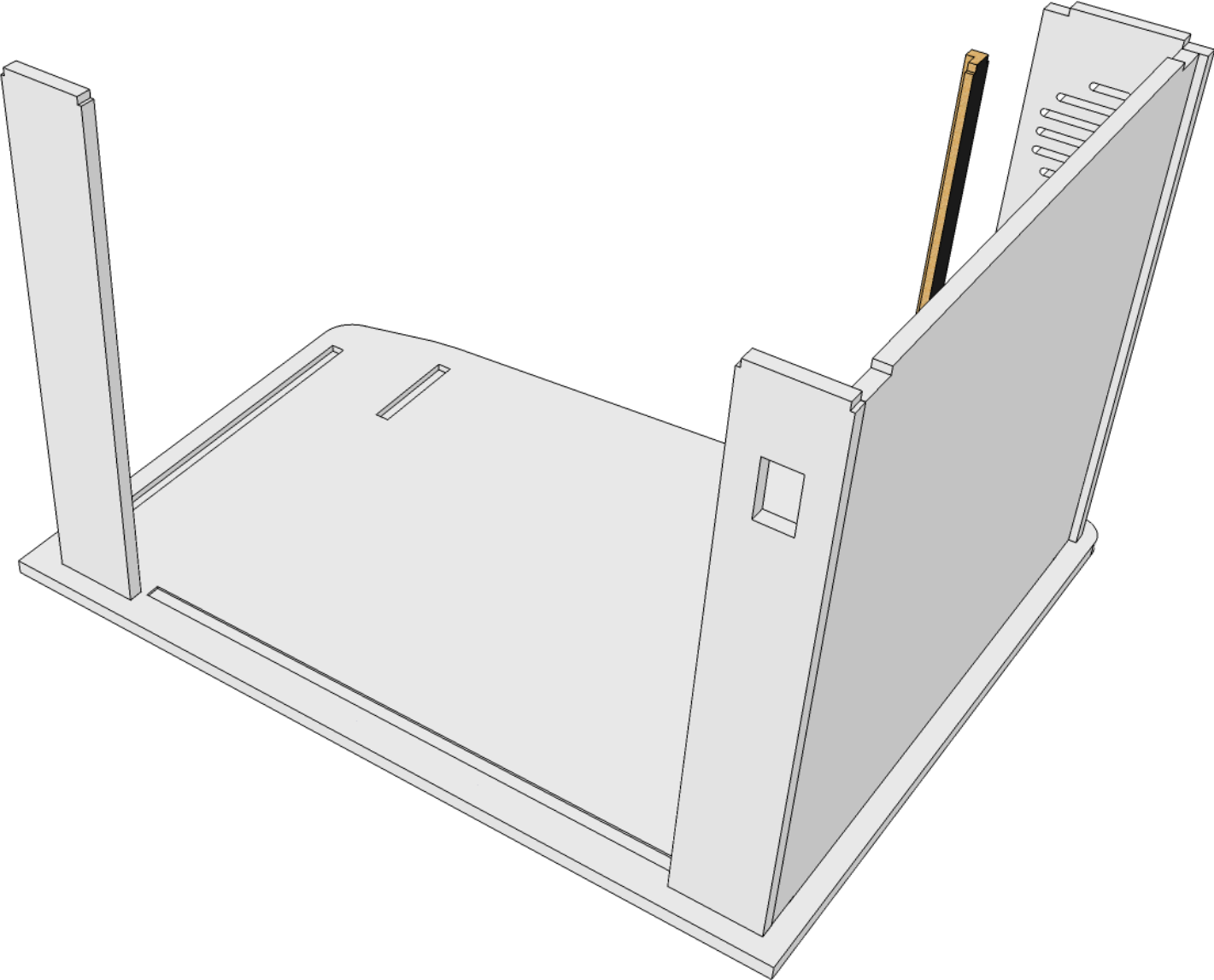

Install the Top Panel and the Lower Marquee Panel as shown. Make sure the T-molding slot cut in the Top Panel faces the rear of the cabinet.

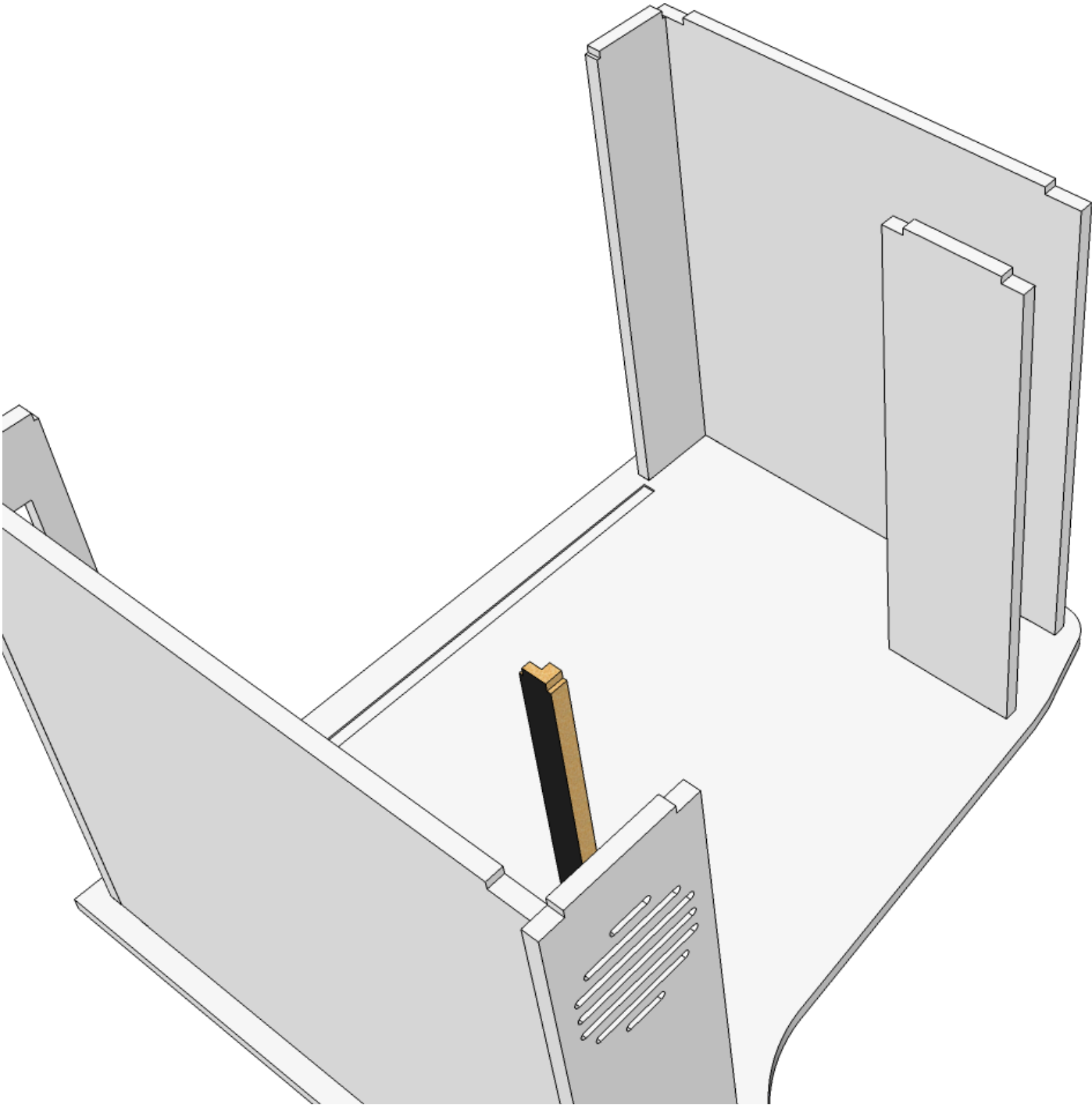

At this time place a long & short baton in the remaining two slots.

Carefully place the remaining side on top (no glue at this time) and line up all the tabs into the slots. When the tabs and slots are aligned, press down. Place a weight on top of the side to apply pressure. Take this time to wipe up any excess glue that may seep from the slots. Let dry overnight.

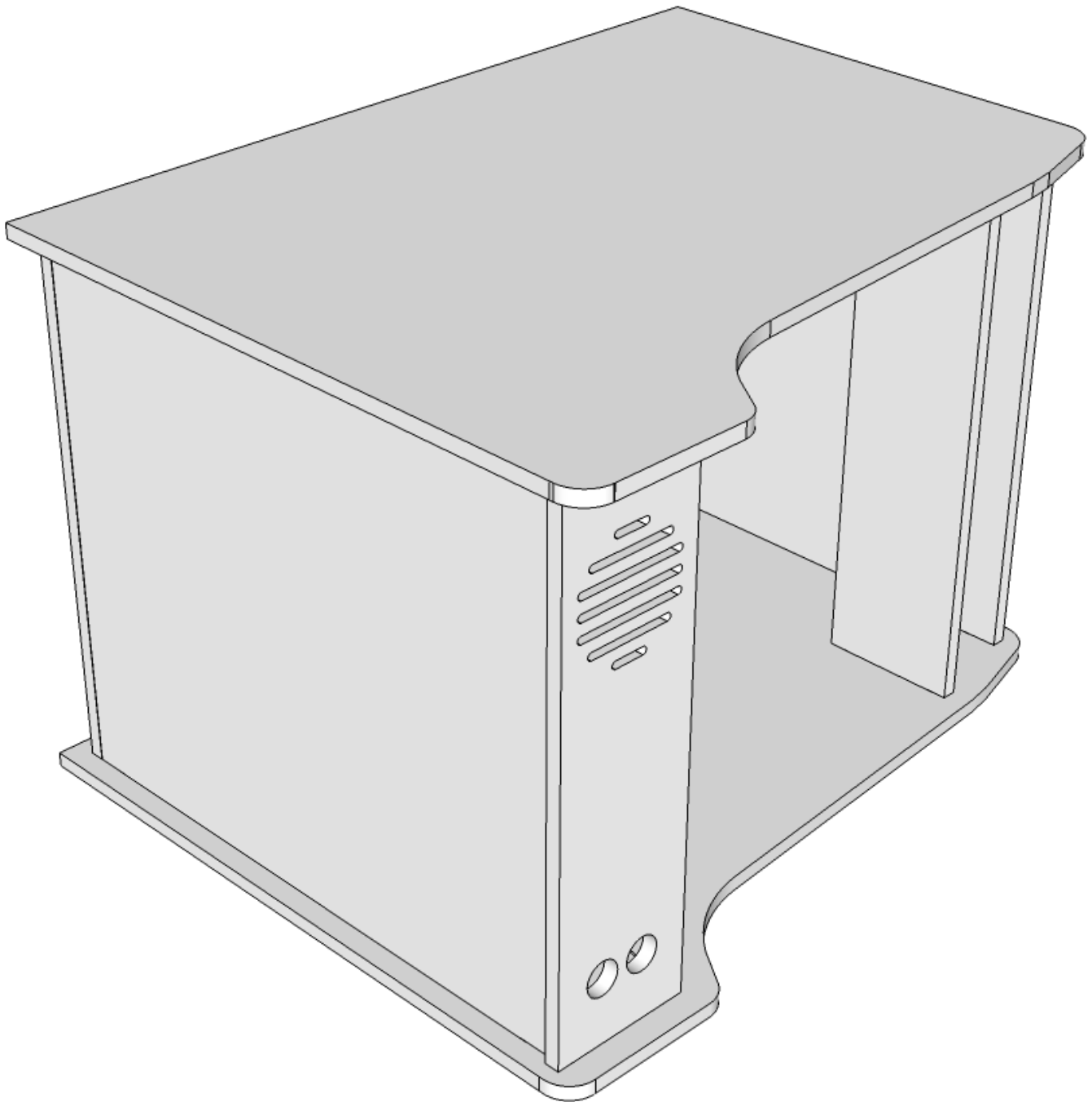

Once the glue has dried overnight, remove the weight and remove the side that wasn't glued. Place that side down on a flat surface, slots facing up, and add glue into the slots. Carefully turn over the glued side / panels assembly and insert the tabs into the correct slots, press down, add a weight, and wipe up any excess glue. Also insert the remaining batons. Let dry overnight.

Monitor mounting:

Once the cabinet is dry, you can complete the monitor mounting. Use the supplied monitor panel to attach to your LCD monitor using M4-.07 machine screws (25mm length). Washers may be needed here. Once this is attached, you can place the monitor and panel into the cabinet to determine where to place the monitor. Once monitor is placed, use the included triangular metal brackets to attach the panel to the sides of the cabinet (drill & ½" wood screws needed).



*** NOTE : The included screws with the brackets are a little too long and will poke out of the cabinet if you use them as is. You either need shorter screws or use some spacers (like washers).**